

M9208-Bxx-3 Series On/Off Electric Spring Return Actuators

Installation Instructions

M9208-BAA-3, M9208-BAC-3, M9208-BDA-3,
M9208-BDC-3, M9208-BGA-3, M9208-BGC-3

Part No. 34-636-2103, Rev. —
Issued October 29, 2008

Applications

The M9208-Bxx-3 Series On/Off Electric Spring Return Actuators are direct-mount actuators that operate on AC 24 V power at 50/60 Hz, DC 24 V power, AC 120 V power at 60 Hz, or AC 230 V power at 50/60 Hz. These bidirectional actuators do not require a damper linkage, and are easily installed on round shafts from 5/16 to 5/8 in. (8 to 16 mm) or square shafts from 1/4 to 1/2 in. (6 to 12 mm) using the standard shaft clamp included with the actuator. An optional M9208-600 Large Coupler Kit is available for round shafts from 1/2 to 3/4 in. (12 to 19 mm) or square shafts from 3/8 to 9/16 in. (10 to 14 mm).

A single M9208-Bxx-3 Series On/Off Electric Spring Return Actuator provides 70 lb-in. (8 N·m) running and spring return torque. Integral line voltage auxiliary switches, available only on the M9208-xxC-3 models, indicate end-stop position, or perform switching functions within the selected rotation range.

IMPORTANT: Use this M9208-Bxx-3 Series On/Off Electric Spring Return Actuator only to control equipment under normal operating conditions. Where failure or malfunction of the electric actuator could lead to personal injury or property damage to the controlled equipment or other property, additional precautions must be designed into the control system. Incorporate and maintain other devices, such as supervisory or alarm systems or safety or limit controls, intended to warn of or protect against failure or malfunction of the electric actuator.

Installation

The M9208-Bxx-3 Series On/Off Electric Spring Return Actuators mount directly to the surface in any convenient orientation using two No. M3-0.5 self-drilling sheet metal screws and the anti-rotation bracket (parts included with the actuator). No additional linkages or couplers are required. Electrical connections are color-coded and identified with numbers permanently marked on the actuator cable. A tag on the actuator cable identifies the electrical connections and wiring details are included on the actuator housing.

IMPORTANT: Do not install or use this M9208-Bxx-3 Series On/Off Electric Spring Return Actuator in or near environments where corrosive substances or vapors could be present. Exposure of the electric actuator to corrosive environments may damage the internal components of the device, and will void the warranty.

Parts Included

- M9208-Bxx-3 actuator
- M9208-603 adjustable stop kit
- M9000-604 anti-rotation bracket with two No. M3-0.5 x 10 mm self-drilling and self-tapping screws
- Manual override crank with 3M™ Dual Lock™ adhesive-backed strip
- Two No. 10-32 x 9/16 in. conduit connector screws

Special Tools Needed

- 10 mm wrench/socket
- drill with 6 mm socket

Dimensions

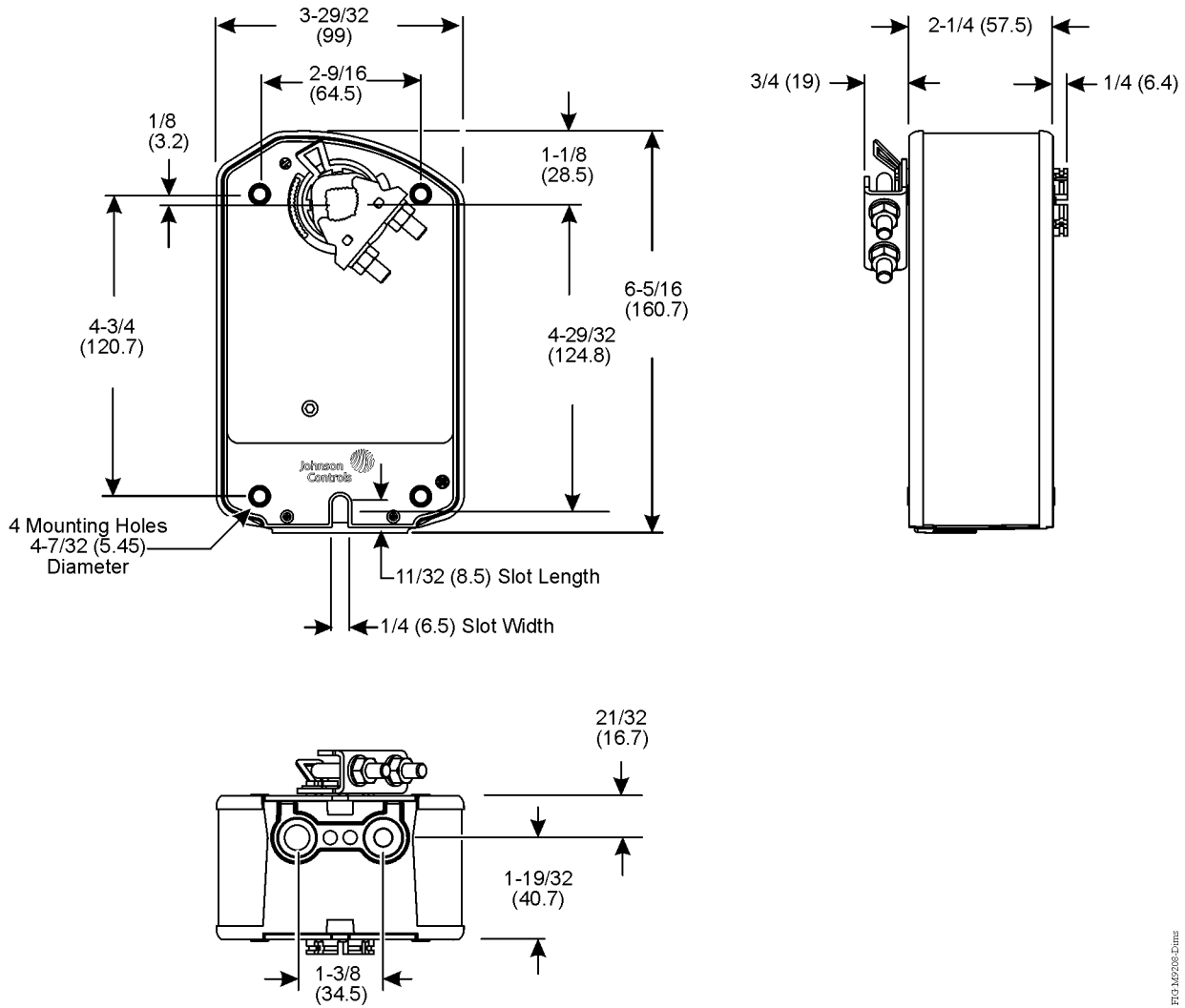

FIG M9208-Dims

Figure 1: M9208-Bxx-3 Series On/Off Electric Spring Return Actuator Dimensions, in. (mm)

Accessories

Table 1: Accessories and Replacement Parts (Order Separately)

Code Number	Description
DMPR-KC003 ¹	7 inch- (178 mm-) Blade Pin Extension (without bracket) for Johnson Controls® Direct-Mount Damper Applications (quantity 1)
M9000-200	Commissioning Tool that provides a control signal to drive 24 V On/Off, Floating, Proportional, and/or Resistive Electric Actuators (quantity 1)
M9000-604	Replacement Anti-Rotation Bracket Kit for M9208, M9210, and M9220 Series Electric Spring Return Actuators (quantity 1)
M9208-100	Remote Mounting Kit, including Mounting Bracket, M9208-150 Crankarm, Ball Joint, and mounting fasteners (quantity 1)
M9208-150	Crankarm (quantity 1)
M9208-600	Large Shaft Coupler Kit (with Locking Clip) for Mounting M9208-xxx-3 Series Electric Spring Return Actuators on dampers with round shafts from 1/2 to 3/4 in. (12 to 19 mm) or square shafts from 3/8 to 9/16 in. (10 to 14 mm) (quantity 1)
M9208-601	Replacement Standard Coupler Kit (with Locking Clip) for mounting M9208-xxx-3 Series Electric Spring Return Actuators on dampers with round shafts from 5/16 to 5/8 in. (8 to 16 mm) or square shafts from 1/4 to 1/2 in. (6 to 12 mm) (quantity 1)
M9208-602	Replacement Locking Clips for M9208-xxx-3 Series Electric Spring Return Actuators (quantity 5)
M9208-603	Adjustable Stop Kit for M9208-xxx-3 Series Electric Spring Return Actuators (quantity 1)
M9208-604	Replacement Manual Override Cranks for M9208 Series Electric Spring Return Actuators with long crank radius: 2.83 in. (72 mm) (quantity 5)
M9208-605	Replacement Manual Override Cranks for M9208 Series Electric Spring Return Actuators with short crank radius: 1.83 in. (46.5 mm) (quantity 5)

1. Furnished with the damper and may be ordered separately.

Mounting

The M9208-Bxx-3 Series On/Off Electric Spring Return Actuators can be easily installed on dampers with round shafts from 5/16 to 5/8 in. (8 to 16 mm) or square shafts from 1/4 to 1/2 in. (6 to 12 mm) using the standard shaft coupler included with the actuator. An optional M9208-600 Large Shaft Coupler Kit adapts to larger shaft sizes; see Table 1 for more details. If the damper shaft extends less than 3.31 in. (84 mm), see the Removable Coupler section for further instructions. If the damper shaft extends less than 0.79 in. (20 mm), install a shaft extension recommended by the damper manufacturer.

Counterclockwise (CCW) Spring Return Direction – Clockwise (CW) Powered Operation

For CCW spring return direction, mount the actuator to the damper shaft so that Side A of the actuator is away from the damper as illustrated in Figure 2. With power applied, the actuator drives CW from the 0° position and spring returns CCW.

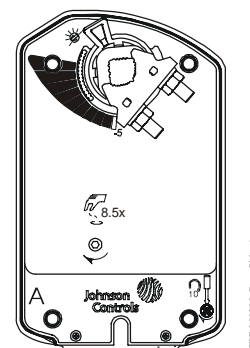

Figure 2: Actuator Side A

Clockwise (CW) Spring Return Direction – Counterclockwise (CCW) Powered Operation

For CW spring return direction, mount the actuator to the damper shaft so that Side B of the actuator is away from the damper as illustrated in Figure 3. With power applied, the actuator drives CCW from the 0° position and spring returns CW.

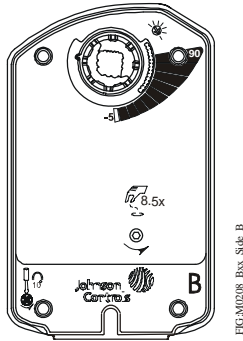

Figure 3: Actuator Side B

Removable Coupler

If the damper shaft extends less than 3.31 in. (84 mm), mount the coupler on the face of the actuator closest to the damper.

If the damper shaft extends less than 0.79 in. (20 mm), a shaft extension is required to mount the actuator.

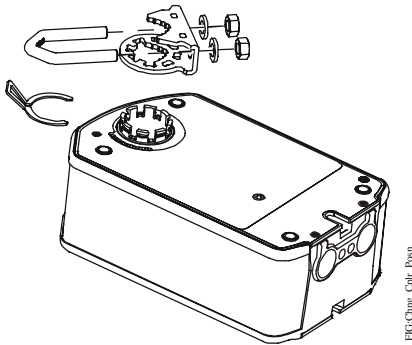

Figure 4: Changing the Coupler Position

To change the coupler's position, see Figure 4 and proceed as follows:

1. Mount the coupler on either Side A or Side B of the actuator as determined by the shaft length.
2. Snap the locking clip securely into the coupler retention groove to retain the coupler.

Manual Override

Use only the supplied manual override crank to reposition the actuator hub when using the manual override feature.

IMPORTANT: Applying excessive torque to the manual override or operating the manual override with a power tool may damage the internal components of the actuator and cause premature failure.

To reposition the actuator hub, proceed as follows:

1. De-energize the actuator.
2. Insert the hex end of the manual override crank into the manual override adjustment point on the face of the actuator.
3. Rotate the manual override crank in the direction indicated by the arrow on the label.
4. The actuator requires 8-1/2 manual override crank rotations from the full spring return position to fully reposition the actuator hub. At the end of travel, the rotation resistance increases. Do not force the manual crank past this point.
5. While holding the manual crank in the wound position, rotate and hold the red lock shaft approximately 10° then release the manual crank to lock the actuator hub in place.

Note: Insert and slightly rotate the manual crank in the direction indicated by the arrow on the label to unlock the actuator hub. Alternatively, the actuator hub automatically unlocks when power is applied to the actuator, and returns the actuator to normal drive and spring return operation.

Mounting the Actuator

To mount the actuator, proceed as follows:

1. See the dimensions in Figure 5 and Table 2 to ensure the correct positioning of the anti-rotation bracket.

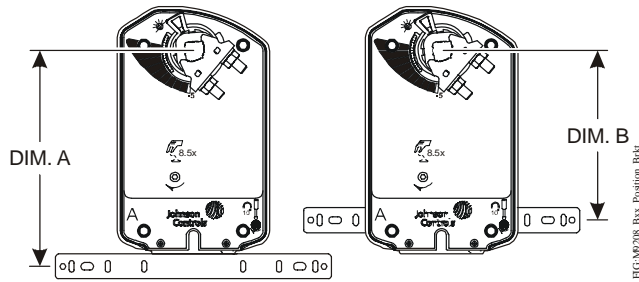

Figure 5: Positioning the Anti-Rotation Bracket

Table 2: Dimensions from Anti-Rotation Bracket to Shaft Center

Shaft Diameter, in. (mm)	Dimension A, in. (mm)	Dimension B, in. (mm)
5/16 to 5/8 (8 to 16)	5-7/16 (138.4)	4-5/32 (105.6)
1/2 to 3/4 (12 to 19)	5-13/32 (137.4)	4-1/8 (104.6)

IMPORTANT: The tab on the anti-rotation bracket must fit midpoint in the actuator slot. Positioning the tab midpoint in the slot prevents actuator binding and premature wear, and makes actuator removal easier.

2. Bend or cut the anti-rotation bracket to fit the damper frame or duct as illustrated in Figure 6.

Note: The anti-rotation bracket can be bent to fit a round damper.
3. Mark or drill mounting holes in the damper frame or duct using the anti-rotation bracket as a guide (based on the measurements obtained in Table 2 and Figure 5).
4. Secure the anti-rotation bracket to the damper frame or duct using the two No. M3-0.5 x 10 mm self-drilling sheet metal screws provided.

IMPORTANT: Do not overtighten the mounting screws to avoid stripping the threads. Be certain that the tab on the anti-rotation bracket remains properly positioned in the slot on the actuator, and that the actuator remains parallel to the mounting surface.

5. Slide the actuator onto the damper shaft, and position the anti-rotation bracket tab into the slot at the bottom of the actuator as illustrated in Figure 6.

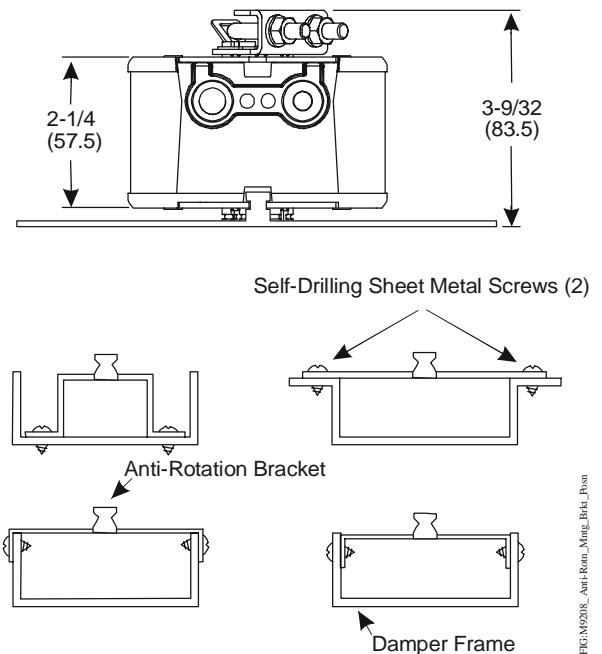

Figure 6: Anti-Rotation Mounting Bracket Positions

6. Rotate the damper blade(s) to the desired position if the power is lost. To ensure a tight seal, insert the manual override crank and turn it in the direction indicated by the arrow. The position indicator should be near the 0° position on the scale. While holding the manual crank in the wound position, rotate and hold the red lock shaft approximately 10° then release the manual crank to temporarily lock the actuator hub in place.
7. Hold the actuator perpendicular to the damper shaft. Evenly hand-tighten each nut on the coupler U-bolt, then torque the coupler U-bolt nuts to 100 to 125 lb-in. (11 to 14 N·m).
8. To manually unlock the actuator hub, rotate the manual override crank slightly in the direction indicated by the arrow and remove it. Alternatively, the hub automatically unlocks when power is applied to the actuator.
9. Store the manual override crank by applying the 3M Dual Lock adhesive-backed strip to the manual crank and a convenient surface of the actuator.
10. Apply power long enough for the actuator to travel a full stroke. Verify that the actuator rotates freely throughout the range.

Note: If electric power is not available, complete this verification by reinserting the manual override crank and turning it in the direction indicated to rotate the hub to the fully open position.

Limiting Rotation Range Using M9208-603 Adjustable Stop Kit

The actuator is factory set for 95° rotation, and its range is limited in 5° increments to a minimum of 35°. A stroke-limiting stop can be attached in the field to the shaft coupler side of the actuator to reduce the rotation range. Attaching the stroke-limiting stop in the furthest mounting position reduces the rotation range of the actuator by 5°. Each progressive mounting position reduces the rotation range an additional 5°.

1. Check that the damper blade is visible or its position is permanently marked on the end of the damper shaft, as illustrated in Figure 7.



Figure 7: Damper Position Icons

2. Position the stroke-limiting stop in the serrated slot with its leading edge at the scale position matching the desired stroke.
3. The product label marks hole positions for the M3-0.5 x 10 mm self-tapping screw provided with the adjustable stop kit. Drive the screw through the slot in the adjustable stop and into the actuator face over a marked hole position. (See Figure 8.)

Note: The minimum rotation range is 35°.

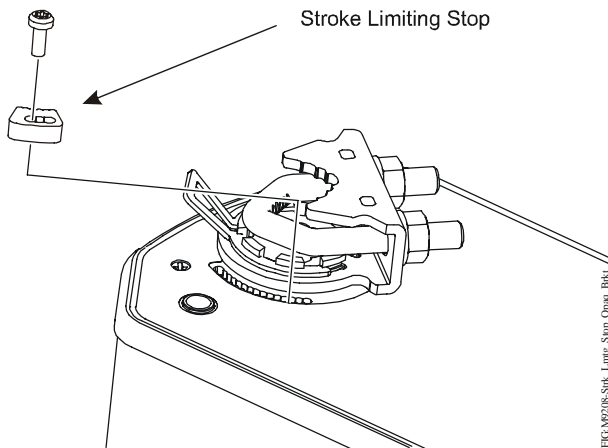

Figure 8: Limiting Rotation Range

Wiring

See Figure 9 and Figure 10 to wire the applicable M9208-Bxx-3 Series model.

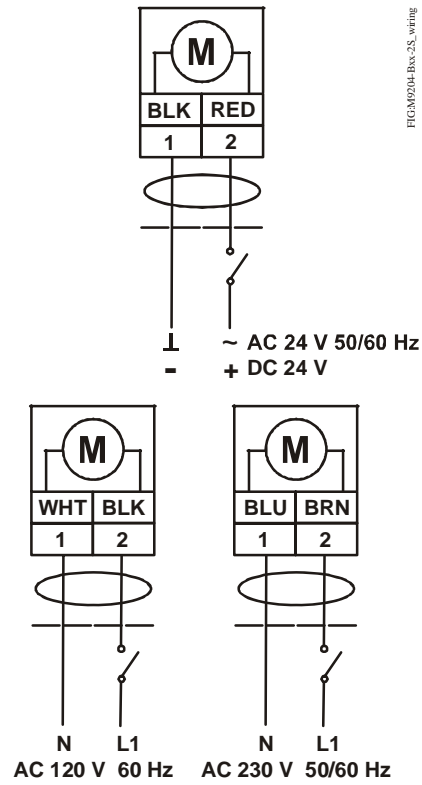

Figure 9: Control Wiring Diagrams

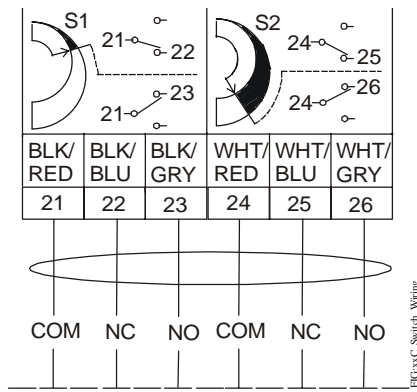

Figure 10: Auxiliary Switch Wiring Diagram

Using Conduit

All M9208 Series Actuators accept 3/8 in. trade size flexible metal conduit.

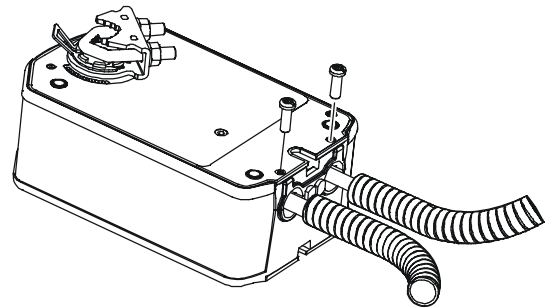

Figure 11: Adding Flexible Metal Conduit

WARNING: Risk of Electric Shock. Disconnect each of multiple power supplies before making electrical connections. More than one disconnect may be required to completely de-energize equipment. Contact with components carrying hazardous voltage can cause electric shock and may result in severe personal injury or death.

CAUTION: Risk of Property Damage. Do not apply power to the system before checking all wiring connections. Short circuited or improperly connected wires may result in permanent damage to the equipment.

CAUTION: Risk of Property Damage. Insulate and secure each unused wire lead before applying power to the actuator. Failure to insulate and secure each unused wire lead may result in property damage.

IMPORTANT: Make all wiring connections in accordance with the National Electrical Code and local regulations. Use proper Electrostatic Discharge (ESD) precautions during installation and servicing to avoid damaging the actuator's electronic circuits.

1. Feed the actuator cables through the field supplied conduit.
2. Push the conduit into the holes in the actuator and secure it with the supplied 10-32 x 9/16 in. screws, as illustrated in Figure 11. The product label marks the position of holes for the screws. Drive the screws through the product label in the marked positions. Drive the screwhead flush with the plate to secure the conduit.

IMPORTANT: Careful workmanship is required to secure flexible metal conduit. Cut the conduit end perpendicular to its axis. Insert the cut end into the bottom of the holes in the actuator and hold the conduit in place while securing it with the screws provided. Check a completed installation by pulling on the conduit to ensure its retention.

Setup and Adjustments

Auxiliary Switch (M9208-xxC-3 Models)

The M9208-xxC-3 models include two integral auxiliary switches with a switch adjuster accessible on either face of the actuator. (See Figure 2 and Figure 3.) The factory setting for Auxiliary Switch No. 1 is 11° closing, and the nominal setting for Auxiliary Switch No. 2 is 81° opening (relative to the 0 to 90° rotation range as printed on the product label). See the [Technical Specifications](#) table for the auxiliary switch ratings.

WARNING: Risk of Electric Shock and Property Damage. Insulate and secure each unused wire lead before applying power to the actuator. Failure to insulate and secure each unused wire lead may result in property damage, electric shock, and severe personal injury or death.

The switch point of Auxiliary Switch No. 1 is fixed. The switch point of Auxiliary Switch No. 2 is independently and continuously adjustable from 25 to 90° position. For the most accurate switch positioning, see Figure 12 and use the method in the following example.

To change the switch point of auxiliary Switch No. 2, proceed as follows:

1. Position the actuator in the full spring return position.

Note: The switch is factory set to trip when the actuator reaches the 81° position.

2. Rotate the switch adjuster until it points to the desired switch point.

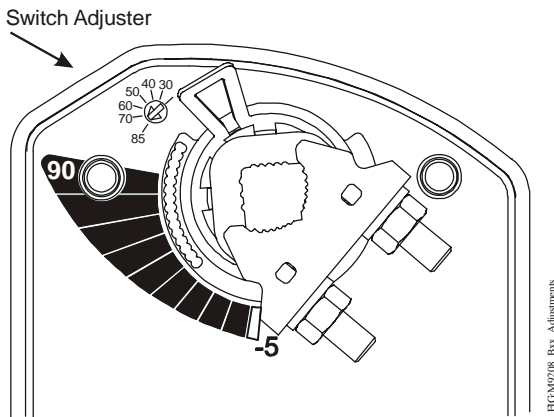

Figure 12: Switch Trip Point Settings

3. Connect Auxiliary Switch No. 2 to a power source or an ohmmeter and apply power to the actuator. The actuator moves to the fully open position and holds while power is applied.
4. Observe the switch point. If required, repeat Step 1 through Step 3.

Repair Information

A number of replacement parts are available; see Table 1 for more details. If an M9208-Bxx-3 Series On/Off Electric Spring Return Actuator fails to operate within its specifications, replace the unit. For a replacement electric actuator, contact the nearest Johnson Controls representative.

Technical Specifications

M9208-Bxx-3 Series On/Off Electric Spring Return Actuators (Part 1 of 2)

Power Requirements	-BGx Models	AC 24 V (AC 18 V to 30 V) at 50/60 Hz: Class 2 (North America) or Safety Extra-Low Voltage (SELV) (Europe), 6.1 VA Running, 1.2 VA Holding Position DC 24 V (DC 21.6 V to 28.8 V): Class 2 (North America) or SELV (Europe), 3.5 W Running, 0.5 W Holding Position Minimum Transformer Size: 7 VA per Actuator
	-BAx Models	AC 120 V (AC 102 V to 132 V) at 60 Hz: 0.05 A Running, 0.03 A Holding Position
	-BDx Models	AC 230 V (AC 198 V to 264 V) at 50/60 Hz: 0.04 A Running, 0.03 A Holding Position
Auxiliary Switch Rating	-xxC Models	Two Single-Pole, Double-Throw (SPDT), Double-Insulated Switches with Gold over Silver Contacts: AC 24 V, 50 VA Pilot Duty AC 120 V, 5.8 A Resistive, 1/4 hp, 275 VA Pilot Duty AC 240 V, 5.0 A Resistive, 1/4 hp, 275 VA Pilot Duty
Spring Return		Direction Is Selectable with Mounting Position of Actuator: Actuator Side A Is Away from Damper or Valve: CCW Spring Return Actuator Side B Is Away from Damper or Valve: CW Spring Return
Rated Torque	Power On (Running)	70 lb-in. (8 N-m) All Operating Temperatures
	Power Off (Spring Returning)	70 lb-in. (8 N-m) at Standard Operating Temperatures 53 lb-in. (6 N-m) at Extended Operating Temperatures
Rotation Range		Maximum Full Stroke: 95° Adjustable Stop: 35 to 95°, Maximum Position
Rotation Time for 90 Degrees of Travel	Power On (Running)	55 to 71 Seconds for 0 to 70 lb-in. (8 N-m) Load, at All Operating Conditions 60 Seconds Nominal at Full Rated Load (0.25 rpm)
	Power Off (Spring Returning)	13 to 26 Seconds for 0 to 70 lb-in. (8 N-m) Load, at Room Temperature 21 Seconds Nominal at Full Rated Load 39 Seconds Maximum with 70 lb-in. (8 N-m) Load at -4°F (-20°C) 108 Seconds Maximum with 53 lb-in. (6 N-m) Load at -40°F (-40°C)
Life Cycles		60,000 Full-Stroke Cycles with 70 lb-in. (8 N-m) Load
Audible Noise Rating	Power On (Running)	<47 dBA at 70 lb-in. (8 N-m) Load, at a Distance of 39-13/32 in. (1 m)
	Power On (Holding)	<20 dBA at a Distance of 39-13/32 in. (1 m)
	Power Off (Spring Returning)	<52 dBA at 70 lb-in. (8 N-m) Load, at a Distance of 39-13/32 in. (1 m)
Electrical Connections	Actuator (All Models)	48 in. (1.2 m) UL 758 Type AWM Halogen-Free Cable with 18 AWG (0.85 mm ²) Conductors and .25 in. (6 mm) Ferrule Ends
	Auxiliary Switches (-xxC Models)	48 in. (1.2 m) UL 758 Type AWM Halogen-Free Cable with 18 AWG (0.85 mm ²) Conductors and .25 in. (6 mm) Ferrule Ends
Conduit Connections		Integral Connectors for 3/8 in. (10 mm) Flexible Metal Conduit
Mechanical Connections	Round Shafts	Range of Sizes: 5/16 to 5/8 in. (8 to 16 mm)
	Square Shafts	Range of Sizes: 1/4 to 1/2 in. (6 to 12 mm)
Enclosure Rating		NEMA 2 (IP54) for All Mounting Orientations
Ambient Conditions	Standard Operating	-4 to 140°F (-20 to 60°C); 95% RH Maximum, Non-Condensing
	Extended Operating	-40 to -4°F (-40 to -20°C); 95% RH Maximum, Non-Condensing
	Storage	-40 to 185°F (-40 to 85°C); 95% RH Maximum, Non-Condensing
Dimensions		6.33 x 3.90 x 2.26 in. (160.7 x 99 x 57.5 mm)

M9208-Bxx-3 Series On/Off Electric Spring Return Actuators (Part 2 of 2)

Compliance	United States	UL Listed, CCN XAPX, File E27734; to UL 60730-1A: 2003-08, Ed. 3.1, Automatic Electrical Controls for Household and Similar Use; and UL 60730-2-14: 2002-02, Ed. 1, Part 2, Particular Requirements for Electric Actuators. (Models: All)
	Canada	UL Listed, CCN XAPX7, File E27734; to UL 60730-1:02-CAN/CSA: July 2002, 3rd Ed., Automatic Electrical Controls for Household and Similar Use; and CSA C22.2 No. 24-93 Temperature Indicating and Regulating Equipment (Models: All).
	Europe	CE Mark, EMC Directive 89/336/EEC (Models: All) CE Mark, Low Voltage Directive 73/23/EEC (Models: -BGC, -BAx, -BDx)
	Australia and New Zealand	C-Tick Mark, Australia/NZ Emissions Compliant (Models: All)
Shipping Weight		Models: -BGC: 3.75 lb (1.7 kg) Models: -BAC and -BDC: 4.15 lb (1.9 kg)

The performance specifications are nominal and conform to acceptable industry standards. For application at conditions beyond these specifications, consult the local Johnson Controls office. Johnson Controls, Inc. shall not be liable for damages resulting from misapplication or misuse of its products.



Building Efficiency
507 E. Michigan Street, Milwaukee, WI 53202

Metasys® and Johnson Controls® are registered trademarks of Johnson Controls, Inc. All other marks herein are the marks of their respective owners. © 2008 Johnson Controls, Inc.